

2-finger parallel gripper pneumatic - series PEP 2-Finger-Parallelgreifer pneumatisch - Typ PEP



Technische Eigenschaften:

- Betriebsdruck: 3 bis 8 bar
- Wiederholgenauigkeit: PEP 10...40 0.02mm; PEP 56...70 0.03mm über 100 Schaltspiele
- Betriebstemperaturbereich von -10°C bis 90°C; bis 130°C und höher auf Anfrage
- Kinematik: Keilhakenprinzip zwangsgeführt über schräge Ebene
- Material : Gehäuse aus hochfester Aluminiumlegierung hartbeschichtet, Funktionsteile aus gehärtetem Stahl
- Betätigung : pneumatisch über gefilterte Druckluft 10µm, trocken oder geölt
- Wartungsfrei: bis 1.5 Mio. Schaltspiele
- Für Innen-und Außengreifen geeignet
- Schutzart IP40
- 24 Monate Garantie

Technical data:

- Range of operating pressure : 3 -8 bar
- Repeatability accuracy: PEP 10...40 0.02mm; PEP 56...70 0.03mm over 100 cycles
- Operating temperature: from -10°C to 90°C; version up to 130° upon request
- Operating principle: wedge-hook kinematics
- Housing material: high tensile hard-coated aluminium alloy, hard-anodized
- Material of functional parts: treated ground steel
- Actuation : compressed air filtered (10 µm), dry or lubricated
- Maintenance: no maintenance required for the first 1.5 million cycles
- Suitable for internal/external gripping
- Rating IP 40
- Warranty 24 months

2-finger parallel gripper pneumatic - series PEP 2-Finger-Parallelgreifer pneumatisch - Typ PEP

VT version

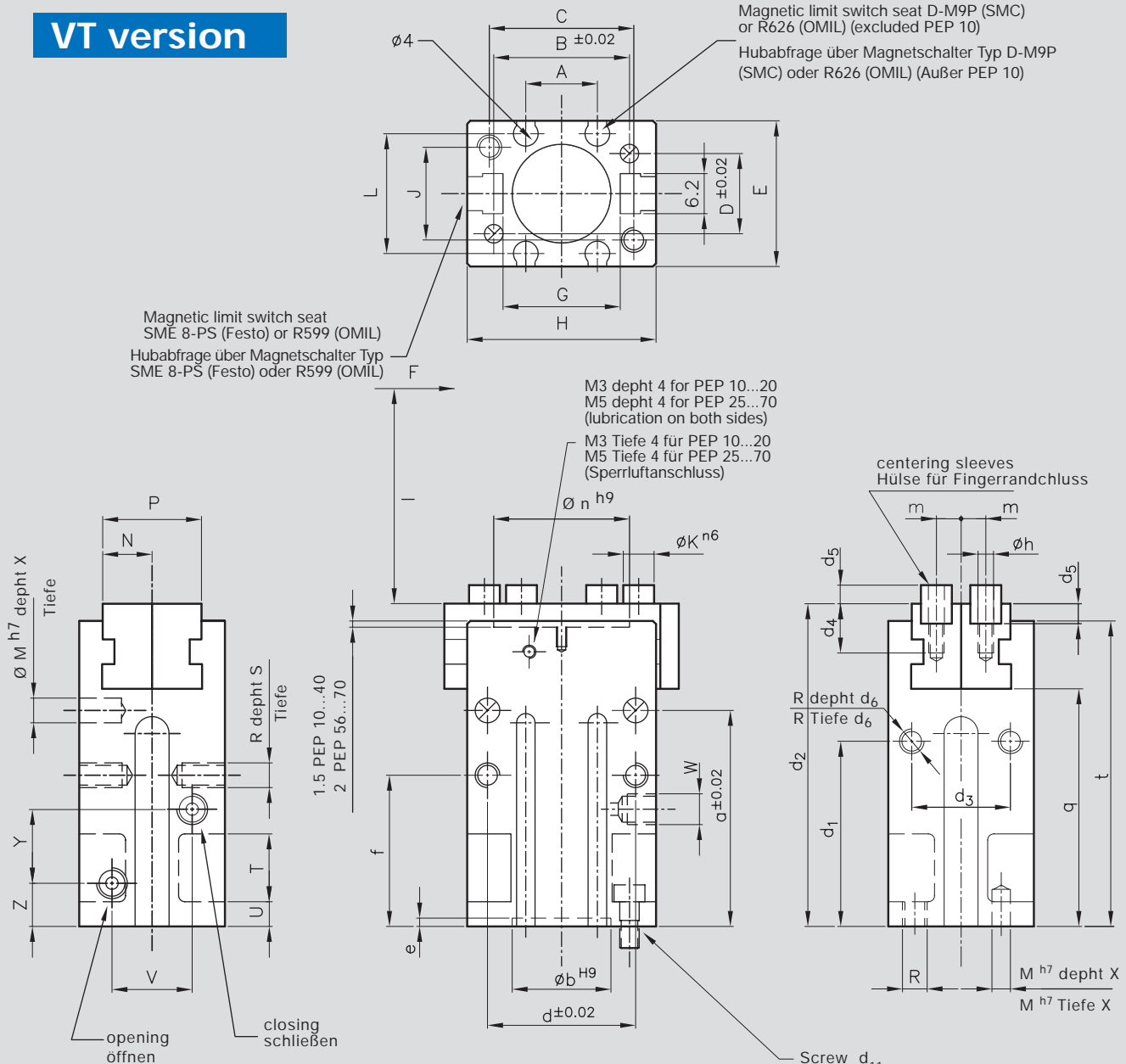

Type	Code 1		Code 2	
	d_8	d_9	d_8	d_9
Typ	Version 1		Version 2	
	d_8	d_9	d_8	d_9
PEP 10	14.5	27	15	27.5
PEP 16	19	35	21	37
PEP 20	26	47	29.5	50.5
PEP 25	33	59	36.5	62.5
PEP 32	41	71	/	/
PEP 40	51	87	/	/
PEP 56	72.5	121.5	/	/
PEP 70	94	156.5	/	/

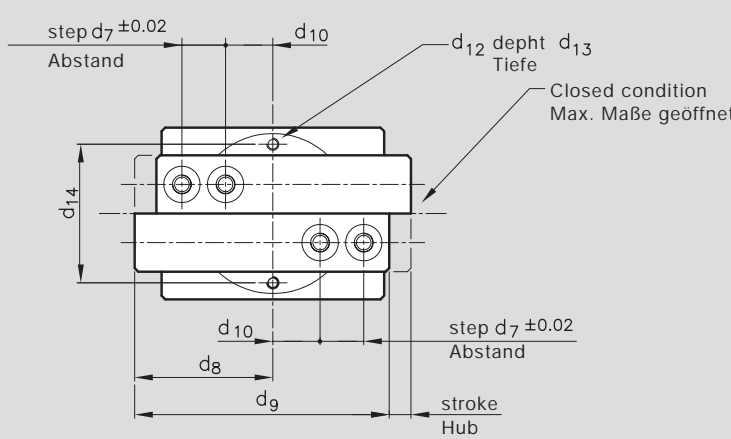

2-finger parallel gripper pneumatic - series PEP 2-Finger-Parallelgreifer pneumatisch – Typ PEP

Type	A	B	C	D	E	G	H	J	L	M	N	P	R	S	T	U	V	Z	Y	X	K	W	a	
Typ																								
PEP 10	/	15.2	18	10.4	16.4	12.6	23	12	/	2	5.8	11.6	M3	5	11	4	11	6.5	12.5	3	4	M3	18	
PEP 16	11.6	22	22	13	23.6	19	30.6	15	19.4	3	8	16	M4	8	11	4	13	7	12	3	5	M5	35	
PEP 20	14	33.6	32	15	27.6	23.2	42	18	23.4	4	9.5	19	M5	10	14	5	15	7.5	15.5	5	6	M5	41	
PEP 25	19	43.6	40	20	33.6	28.4	52	22	26.6	4	11	22	M6	14	15	5	20	9.3	14.7	5	8	M5	43	
PEP 32	24	46	46	24	40	37	60	26	37	5	13	26	M6	16	21	7	24	11	21	5	8	M5	54	
PEP 40	29.4	58	56	28	48	45.8	72	32	45.8	5	16	32	M8	16	26	10	28	11	29	5	12	M5	65	
PEP 56	30	82	82	48	64	60	98	48	60	6	19	38	M10	18	29	10	21	10	37	9	12	1/8	44	
PEP 70	34	106	106	60	79	75	125	60	75	8	23	46	M12	18	40	14	40	12	53	12	15	1/8	62	

Type	b	d	d ₁	d ₂	d ₃	d ₄	d ₅	d ₆	d ₇	d ₁₀	d ₁₁	d ₁₂	d ₁₃	d ₁₄	e	f	h	l	m	n	q	t	
Typ																							
PEP 10	11	16	27	45	11.4	7	3	6	5	4.5	M2.2	/	/	/	2	23	M2	10	2.8	/	32	42.5	
PEP 16	17	24	30	52.3	16	8	3	5	6	6.5	M3	M2	5	20	2	24.5	M2.5	15	4	22.6	38.5	49.5	
PEP 20	21	30	35	64.8	18.6	10	4	10	8	8.5	M4	M2	6	23.6	3	29	M3	20	4.5	26.6	47.5	62	
PEP 25	26	36	36.5	77.7	22	12	4	10	10	10	M5	M2.5	7	27.6	3.5	30	M4	20	5.5	32	55.2	74.7	
PEP 32	34	46	48	84	26	12	4	10	12	12	M5	M3	8	33	4	40	M4	25	6.5	38	58.5	80	
PEP 40	42	56	58	103	32	18	6	13	16	12	M6	M4	10	40	4	49	M6	25	8	46	70	99	
PEP 56	/	80	/	127	/	18	5	/	16X2	9	M8	M5	12	51	/	58	M6	30	10	60	80	125	
PEP 70	/	106	/	170	/	21	6	/	20X2	12.5	M10	M6	13	62	/	80	M8	40	11	75	108.5	167	

Type	Stroke for finger (mm)		Gripping force at 6 bar (N)		Total air for double stroke consumed (cm ³)	Moment of inertia (Kgcm ²)	Mass (kg)	Recommended weight of part for transport (kg)		Approx. time (s)		Max finger length / weight
	code 1	code 2	code 1	code 2				code 1	code 2	opening	closing	
Typ	Hub pro Finger (mm)		Greifkraft 6 bei bar (N)		Luftverbrauch pro Doppelhub (cm ³)	Massenträgheitsmoment (Kgcm ²)	Masse (kg)	Max. empfohlenes Werkstückgewicht (kg)		Schließzeit (s)		Max. Fingerlänge/Eigenmasse
	Vers 1	Vers 2	Vers 1	Vers 2				Vers 1	Vers 2	öffnen	schließen	
PEP 10	2	3.5	30	16	0.45	0.027	0.055	0.15	0.08	0.03	0.03	25/0.015
PEP 16	3	5.5	94	54	1.85	0.12	0.13	0.45	0.27	0.04	0.04	32/0.04
PEP 20	5	8.5	150	86	4.8	0.36	0.23	0.75	0.43	0.05	0.05	42/0.08
PEP 25	7	10.5	200	140	8.7	1.08	0.45	1	0.7	0.05	0.05	52/0.18
PEP 32	11	/	290	/	19	2.44	0.75	1.5	/	0.06	0.06	60/0.38
PEP 40	15	/	445	/	40.5	6	1.28	2.3	/	0.1	0.1	75/0.68
PEP 56	23.5	/	950	/	130	22.3	2.6	4.8	/	0.15	0.15	100/1.42
PEP 70	31.5	/	1440	/	266	71	5.2	7.3	/	0.25	0.25	125/2.35

Transportable weight calculated with $\mu = 0.1$ and $f_s = 2$. With form-fit gripping the mass may be greater. The gripping force is the arithmetic sum of the individual forces created at the fingers at "l" mm distance at 6 bar finger weight in Kg.

Empfehlung für max. Werkstückgewicht gerechnet mit $\mu = 0.1$ $f_s = 2$. Bei Formschluss sind größere Massen möglich. Die Greifkraft ist die arithmetische Summe der an den Greifbacken auftretenden Einzelkräfte im Abstand "l" in mm bei 6 bar. Eigenmasse in Kg.

2-finger parallel gripper pneumatic - series PEP 2-Finger-Parallelgreifer pneumatisch - Typ PEP

VS version

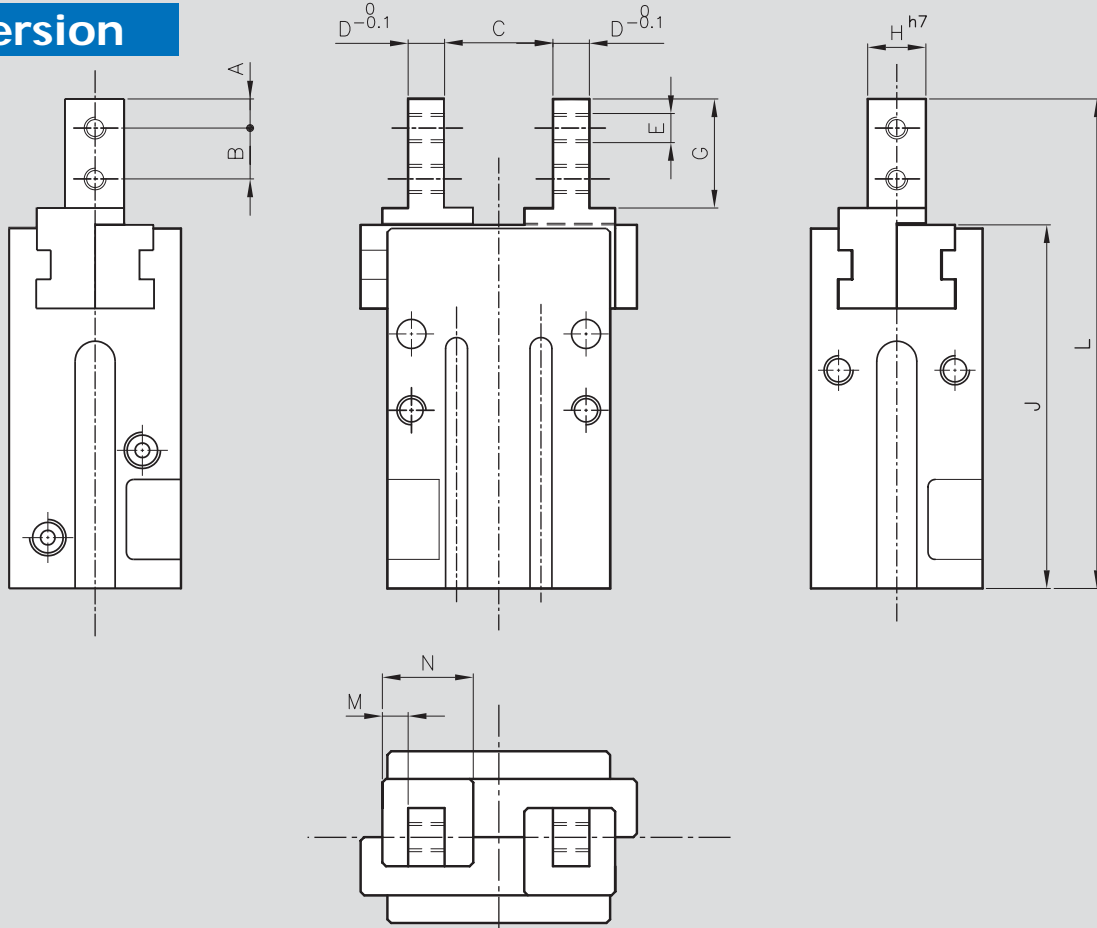

Type Typ	A	B	C	D	E	G	H	J	L	M	N
PEP 10	3	5.7	11.2	4	M2.5	12	5	43.2	57	2.9	9.8
PEP 16	4	7	14.9	5	M3	15	8	50	67.3	3.5	12.5
PEP 20	5	9	16.3	8	M4	20	10	63	84.8	4.8	18
PEP 25	6	12	19.3	10	M5	25	12	75	102.7	6.3	22.5
PEP 32	7	14	26	12	M6	29	15	81	113	5	25
PEP 40	9	17	30	14	M8	36	18	100	139	7	30

Allowed load data

Maximal zul.
Kräfte und
Momente am
Finger

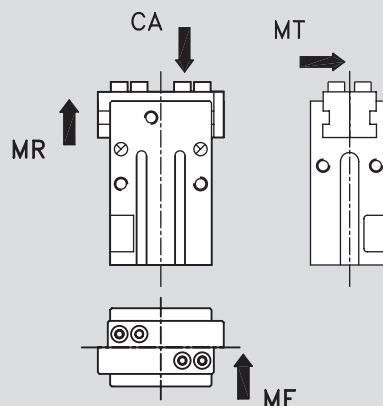

Type Typ	CA (N)	MR (Nm)	MF (Nm)	MT (Nm)
PEP 10	100	1	2	0.7
PEP 16	180	2.5	4	2
PEP 20	300	5	6.5	2.5
PEP 25	350	10	8	4
PEP 32	500	16	14	6
PEP 40	600	18	16	10
PEP 56	800	20	20	15
PEP 70	1000	40	40	25

2-finger parallel gripper pneumatic - series PEP 2-Finger-Parallelgreifer pneumatisch - Typ PEP

Force at 6 bar in N at l mm

Greifkraft (N) in Abhängigkeit der Fingerlänge "l" (mm) bei 6 bar

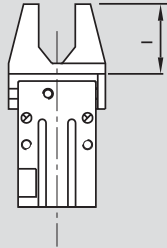

Code 1 Version 1 (solid line)
Code 2 Version 2 (dashed line)

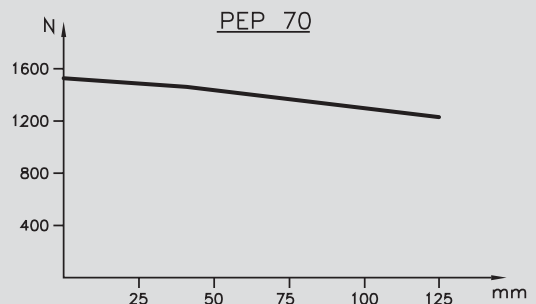
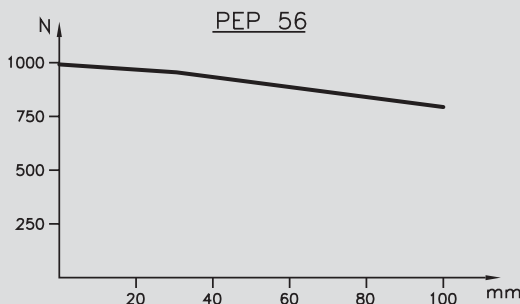
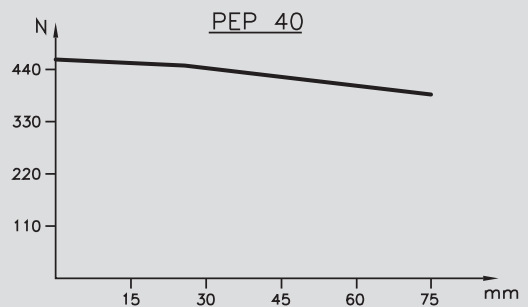
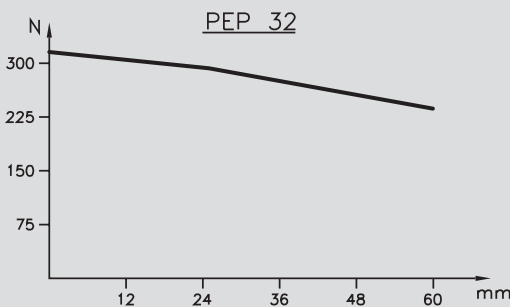
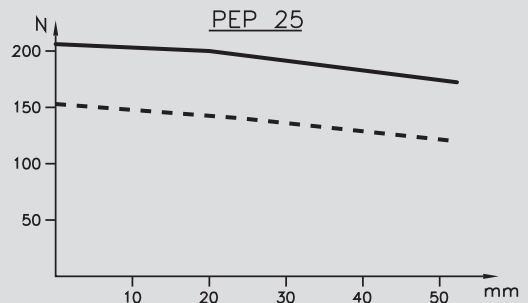
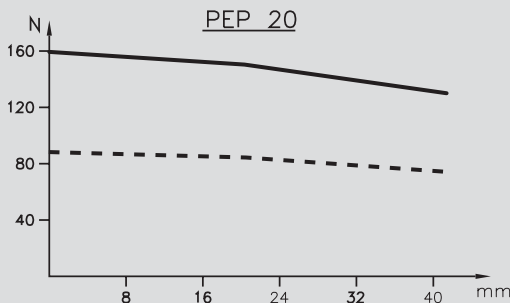
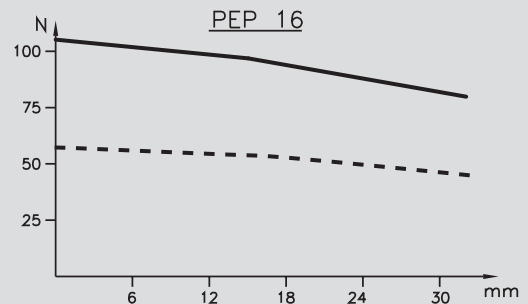
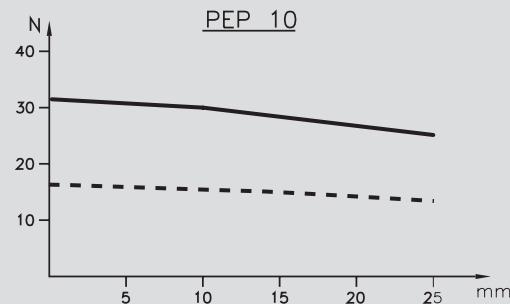

2-finger parallel gripper pneumatic - series PEP 2-Finger-Parallelgreifer pneumatisch - Typ PEP

Safety device to preserve gripping force
code MC (closing) MA (opening)

Ausführung mit Greifkraftsicherung
Version MC (schließen) MA (öffnen)

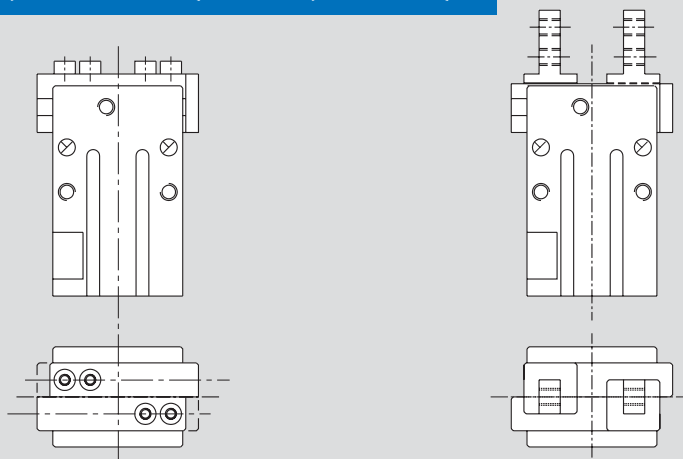

Type	Gripping force only with spring in N with fixed elasticity				Gripping force only with spring in N with fixed elasticity				Approx. gripping time (s) with spring only	
	code 1 closing		code 2		code 1 opening		code 2		min	max
	min	max	min	max	min	max	min	max	min	max
Typ	Greifkraft über Feder abgesichert außen Spannen				Greifkraft über Feder abgesichert Innen spannen				Schließzeit nur über Feder (s)	
	Vers 1		Vers 2		Vers 1		Vers 2		min	max
	min	max	min	max	min	max	min	max	min	max
PEP 10	8.5	15	5	9	4	8.5	2.3	5	0.03	0.03
PEP 16	27	39	15	22	4	23	2.3	13	0.03	0.04
PEP 20	25	53	14	31	15	55	8.7	32	0.03	0.06
PEP 25	47	74	33	52	30	50	21	35	0.03	0.07
PEP 32	45	108	/	/	46	82	/	/	0.05	0.10
PEP 40	60	140	/	/	61	125	/	/	0.08	0.14
PEP 56	135	280	/	/	/	/	/	/	0.15	0.25
PEP 70	200	370	/	/	/	/	/	/	0.22	0.40

NOTE: Minimum operating pressure 0.45 MPa. Upon request versions with lower operating pressure; in this case the force of the spring will be less.

Gripping force = Pneumatic gripping force + spring gripping force.

Gripping force is the arithmetic sum of the individual forces of the fingers.

Bemerkung: Betriebsdruck mindestens 4.5 bar

Die Greifkraft ergibt sich aus der pneumatischen Greifkraft + Federkraft

Die Greifkraft ist die arithmetische Summe der an den Greifbacken auftretenden Einzelkräfte im Abstand "l" bei 6 bar

Ordering example

Bestellbeispiel

Type	Code 1 or 2	For finger version indicate VS or VT	For safety device indicate MC or MA
Typ	Vers 1 or 2	Für Version Grundbacke VS oder VT	Greifkraftsicherung Ausführung MC oder MA
PEP 16	C1	VT	MC